

Locobuffer Manual

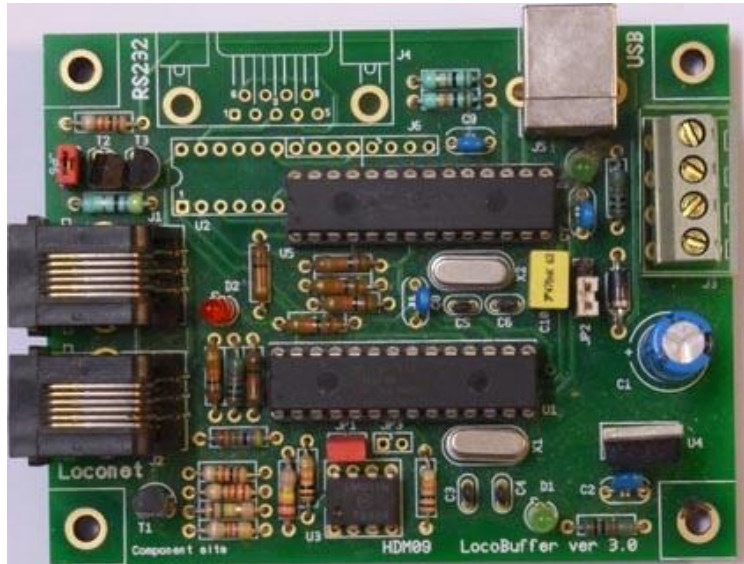

HDM09

Liability disclaimer:

Use all items that can be bought and installation instructions that can be found on this site at your own risk. They have been developed for personal use, and I find them very useful. That is why I wish to share them with other model railroad hobbyists. All items and procedures have been tested and used on my own model railroad systems without causing any damage, but this does not necessarily imply that all modifications and procedures will work in any and all environments or systems. I cannot take any responsibility when items or procedures are used under different circumstances. Always use your own judgement and common sense!

Locobuffer 3.0

LocoBuffer is a hardware device that provides a hardware interface between a Loconet and a RS232 serial port or USB virtual serial port. Takes Loconet commands in and buffers it and sends it out the serial port at 16457 baud in MS100 compatible mode, 19200 or 57600 baud in LocoBuffer mode or to the USB. Takes serial port commands in at 16457, 19200 or 57600 baud or from USB and buffers it and sends it out on the Loconet. It also does them both at the same time. The baud rate is jumper selectable for the RS232 interface and automatic for the USB. It provides all the timing necessary to interface both.

The data you get will be full packets. The binary data will be packets that are 2,4,6 or multi byte in length. They will contain the data as documented in the *Digitrax LocoNet Personal Edition 1.0*.

To connect LocoBuffer to a computer you need a straight thru DB9 serial cable and can be purchased in any computer store or electronic store. You also need a cable to connect the LocoBuffer to the LocoNet. This cable will have 6 wires and RJ12 connectors on both ends.

Because of the used windows driver can only be 1 LocoBuffer connected on a PC.

You may connect multiple PC's with a LocoBuffer on LocoNet.

Loconet connection:

The connection to Loconet is with a 6-wire cable with RJ12 connectors. Important is that on the connector on both ends of the cable the pin1 to pin1 is connected.

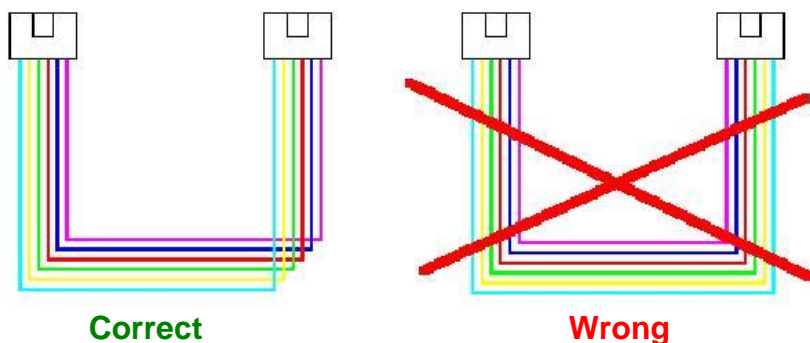

Correct

Wrong

RS232 verbinding



USB verbinding



Bill of materials:

UT_DEVICE	Refdes		USB		RS232
PCB		1	HDM09V30	1	HDM09V30
IC-Socket	For U1	1	28 pins	1	28 pins
IC-Socket	For U5	1	28 pins	0	X
Resistor	R1,R8	2	1kΩ (Brown,Black,Red,Gold)	2	1kΩ (Brown,Black,Red,Gold)
Resistor	R16	1	1kΩ (Brown,Black,Red,Gold)	0	X
Resistor	R2	1	220kΩ (Red,Red,Yellow,Gold)	1	220kΩ (Red,Red,Yellow,Gold)
Resistor	R3	1	22kΩ (Red,Red,Orange,Gold)	1	22kΩ (Red,Red,Orange,Gold)
Resistor	R4,R10,R11, R12,R13,R15,R19	7	10kΩ (Brown,Black,Orange,Gold)	7	10kΩ (Brown,Black,Orange,Gold)
Resistor	R14,R17,R18,R20, R21,R22	6	10kΩ (Brown,Black,Orange,Gold)	0	X
Resistor	R5	1	47kΩ (Yellow,Violet,Orange,Gold)	1	47kΩ (Yellow,Violet,Orange,Gold)
Resistor	R6	1	150kΩ (Brown,Green,Yellow,Gold)	1	150kΩ (Brown,Green,Yellow,Gold)
Resistor	R7	1	4k7Ω (Yellow,Violet,Red,Gold)	1	4k7Ω (Yellow,Violet,Red,Gold)
Resistor	R9	1	47Ω (Yellow,Violet,Black,Gold)	1	47Ω (Yellow,Violet,Black,Gold)
Elco	C1	1	100μF/25V	1	100μF/25V
Capacitor	C2,C8	2	100nF (104)	2	100nF (104)
Capacitor	C7,C9	2	100nF (104)	0	X
Capacitor	C3,C4	2	15pF (15)	2	15pF (15)
Capacitor	C5,C6	2	15pF (15)	0	X
Capacitor	C10	1	470nF (474)	0	X
Diode	D3	1	1N4001 or 1N4002	1	1N4001 or 1N4002
LED 3mm	D1	1	Green	1	Green
LED 3mm	D4	1	Green	0	X
LED 3mm	D2	1	Red	1	Red
Transistor	T1	1	BC337-40	1	BC337-40
Transistor	T2,T3	2	BC547B	2	BC547B
Power IC	U4	1	7805	1	7805
Comparator IC	U3	1	LM311N	1	LM311N
XTAL	X1	1	Quartz 20MHz	1	Quartz 20MHz
XTAL	X2	1	Quartz 20MHz	0	X
Jumper	JP1,JP6	2	2 pins	2	2 pins
Jumper	JP3	0	X	1	2 pins
Jumper	JP2	1	3 pins	1	3 pins
Connector	J1,J2	2	RJ12	2	RJ12
Connector	J3	1	4 pins print connector	1	4 pins print connector
Connector	J4	0	X	1	9 pin sub-d female
Connector	J5	1	USB type B	0	X
RS232 interface	U2	0	X	1	MAX233CPP or SP233ACP or ADM233LJN
PIC processor	U1	1	LB164	1	LB164
PIC processor	U5	1	USB001	0	X
Spacer		4	Nylon 6.6, 5x5mm	4	Nylon 6.6, 5x5mm

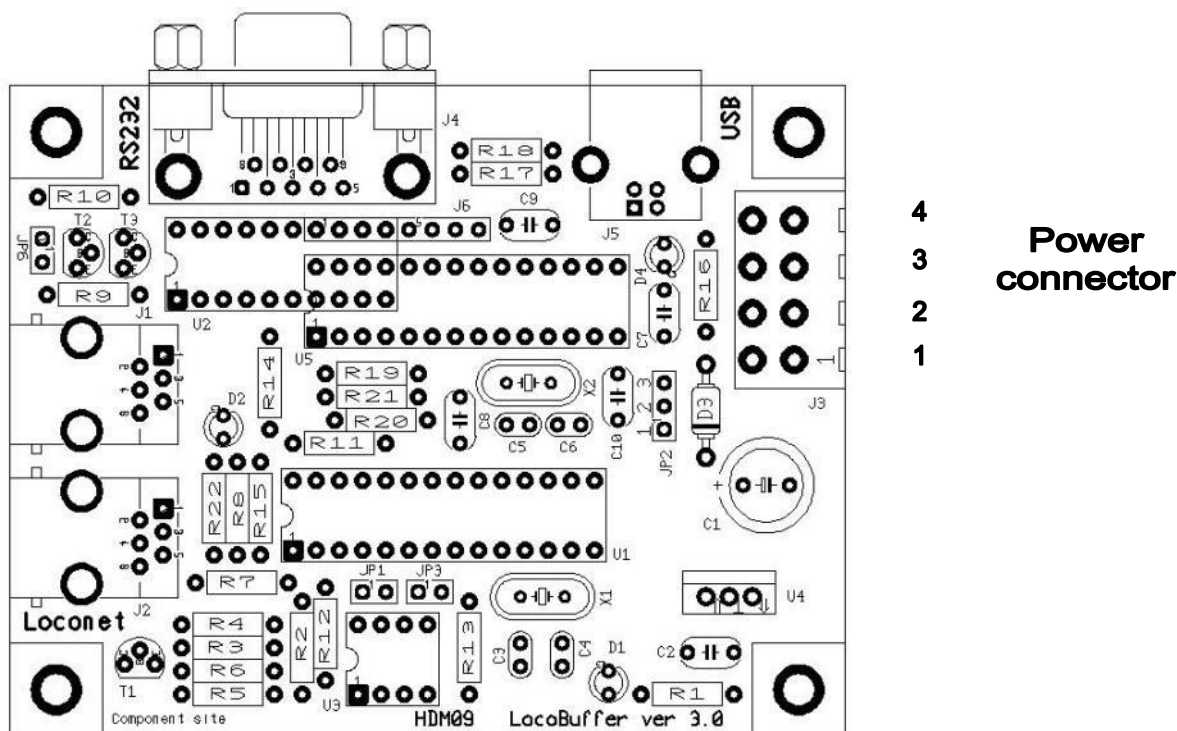

4
3
2
1

**Power
connector**

Green LED's:

On Power supply voltage OK
Off No power supply present

Red LED:

On No central station connected or current source on LocoBuffer with JP6 selected.
Off Loconet OK, no activity
Blinking Loconet command transfer

Jumper settings:

JP1: OFF 19200 baud for RS232
ON 57600 baud for RS232 and USB

JP2: 1-2 5V power for the module with external power supply
2-3 5V power for the module from the USB connection
A USB 1.0 and some USB connections of Laptops do not give enough power.

JP3 : OFF LocoBuffer mode with JP1 selectable serial speed
ON MS100 compatible mode

JP6: OFF LocoNet current source disabled
ON LocoNet current source enabled

This is current source for LocoNet to install if you do not have a master LocoNet control station as an LocoCentral, Intellibox, Digitrax... There is only one current source needed for a LocoNet line. If you install the components, you can enable-disable it with JP6. However, for this option you need to put power on the Power connector.

Power connector possibilities:

Input:

Pin 2: 12V-15V DC input
Pin 4: GND input

Output:

Pin 1: 5V output
Pin 4: GND output

Remark:

Hans Deloof
info@locohdl.be
<https://www.locohdl.be>

Version 18/01/2023

- Put the PIC on an IC socket, then you can later install an update PIC.
- If your XTAL component is in metal, look that there is no contact between the metal surface of the XTAL and the solder holes.
- With a DC power supply is the GND the same as an Intellibox or LocoBooster.

USB Interface



Serial interface RS232

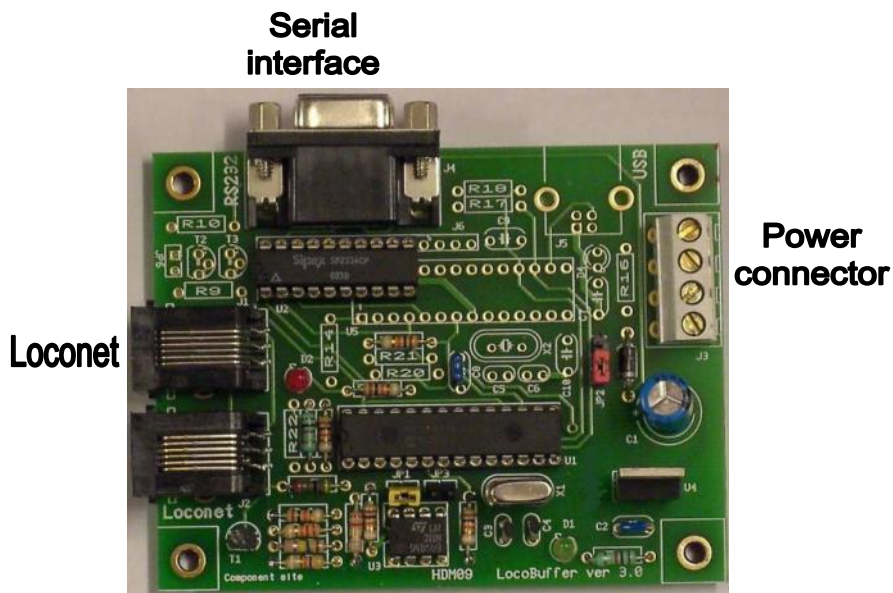

Railroad & Co

Some USB to serial adapters are not fully compliant to regular serial ports. To use these with LocoBuffer, it is possible that next option in RAILROAD.INI is necessary, if no connection can be made.

```
[Connections]
ComOption=0
```

Computer settings with RS232:



For good functioning of the LocoBuffer the "Flow control" must stand on "hardware" for the RS232 version.

Computer settings with USB for Windows 2000, XP, Vista:

Install first LocoHDL configuration programme version 3.6.1 or higher on your PC.

Connect the LocoBuffer to the computer with a USB cable, put then power on the module. The next picture appears on the screen:



Click on "Next"



Click on "Next"



Fill in as on above screen and click on “Next”



Wait



Click on “Finish”

The USB driver for LocoBuffer is now installed.

To know which virtual serial port has been linked with the LocoBuffer, you do the following:
Open the Control Panel from the Start menu.

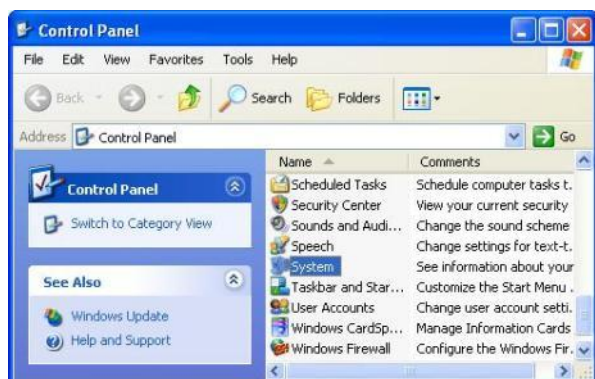

Double click on “System”



Click on “Device Manager” in Hardware tab page

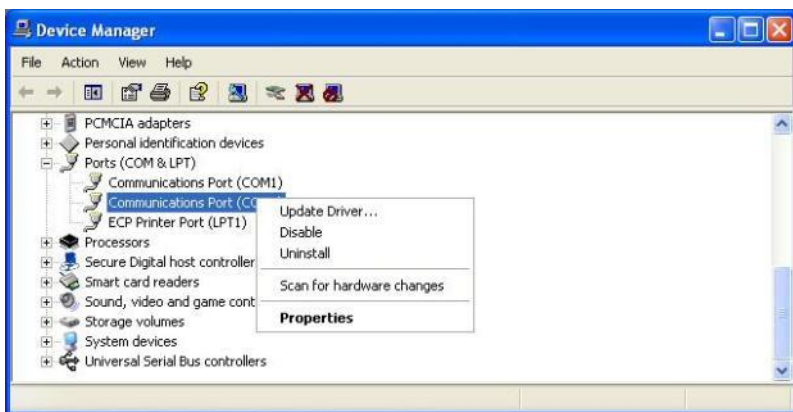

Look at the “Properties” of the different Communication Ports



In this example is the LocoBuffer on Com4.

Computer setting with USB for Windows 7 and Windows 8:

Install first LocoHDL configuration programme version 3.6.1 of higher on your PC.
 Connect the LocoBuffer to the computer with a USB cable, put then power on the module.
 The PC communicates that no devices driver is found but is as device present.
 For installing the device driver, open the Control Panel

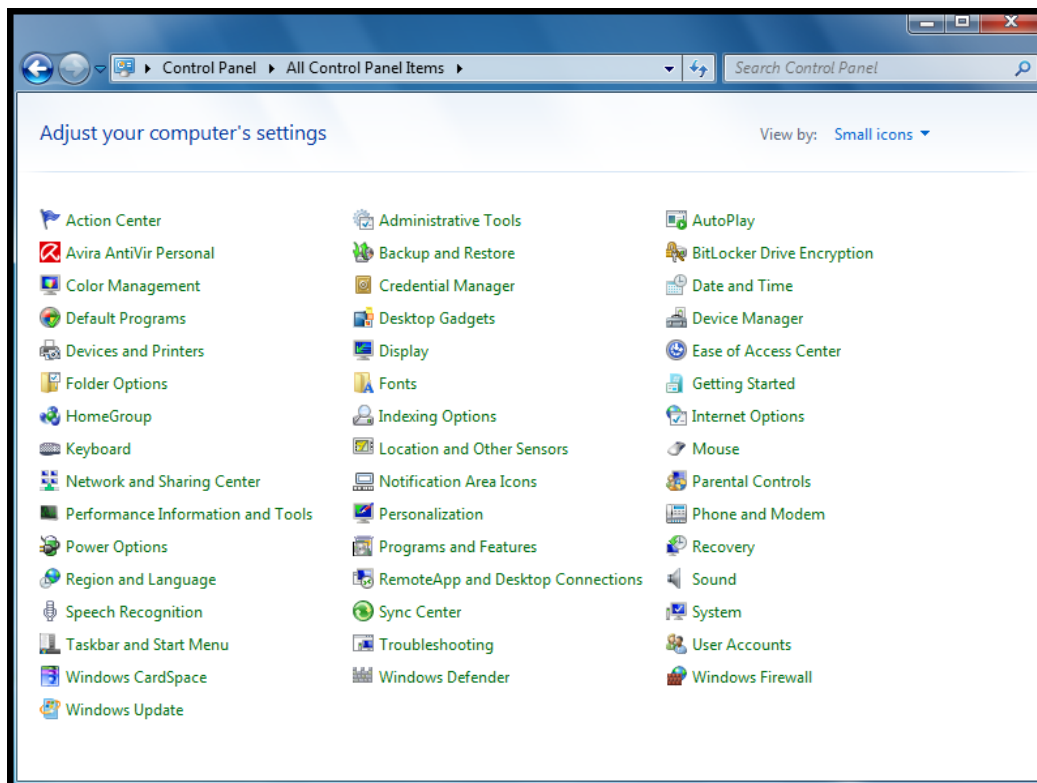

Click on "Device Manager"

Here you see the application
 "CDC RS232 Emulation LocoHDL"

Double click on the announcement

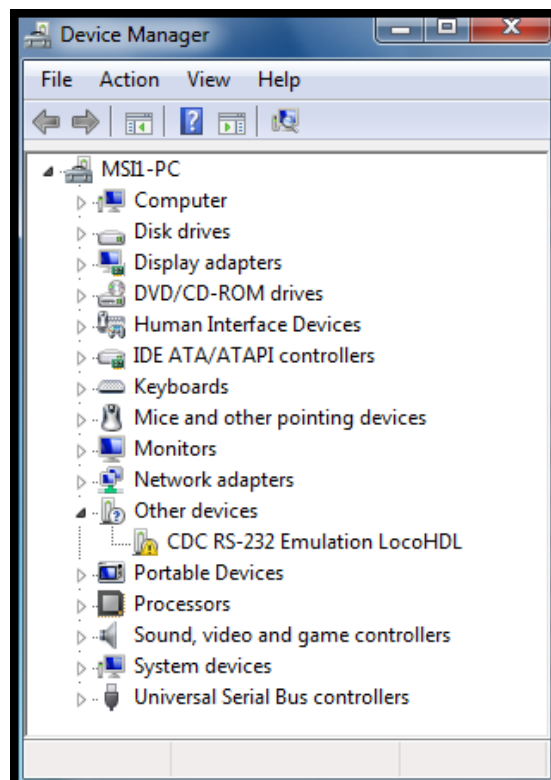

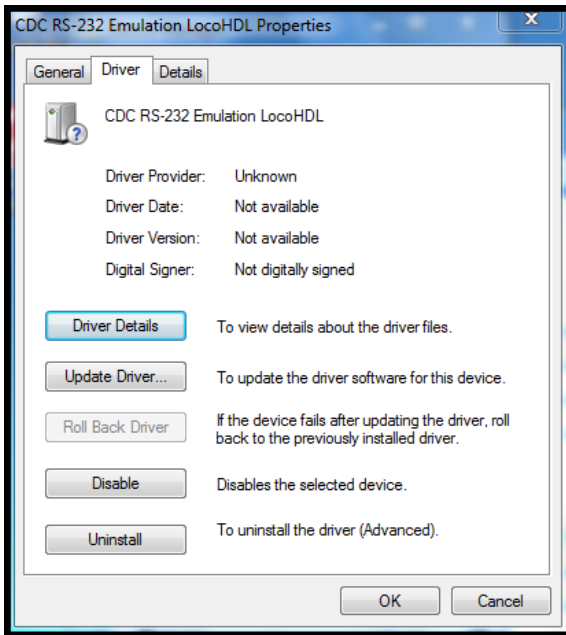

Click on "Update Driver"

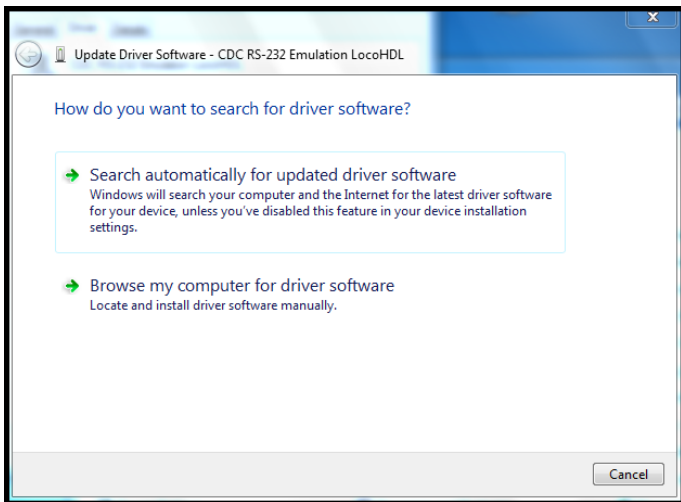

Click on "Browse my computer for driver software"

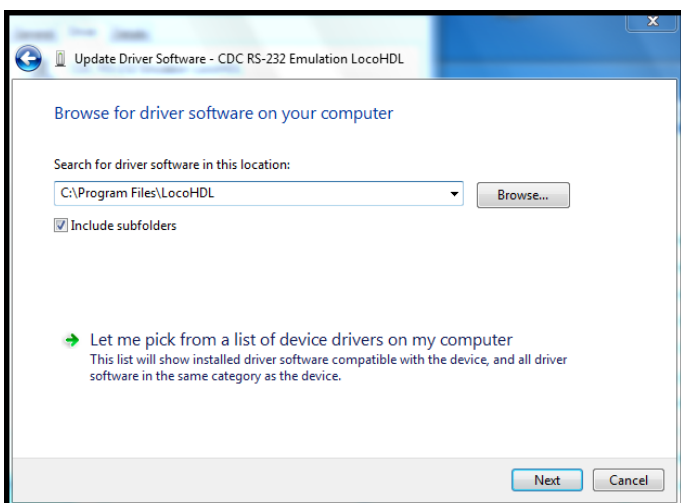

Fill in above location "C:\Program Files\LocoHDL",

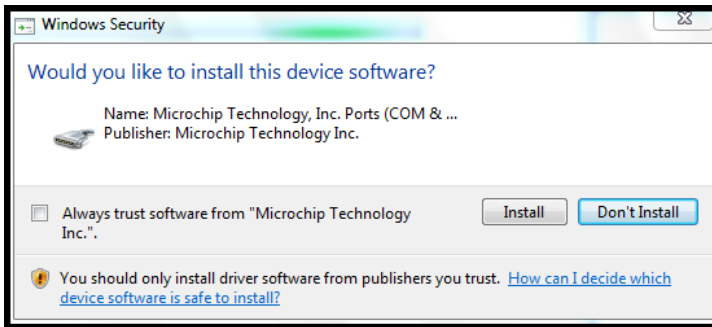

Click on "Install"

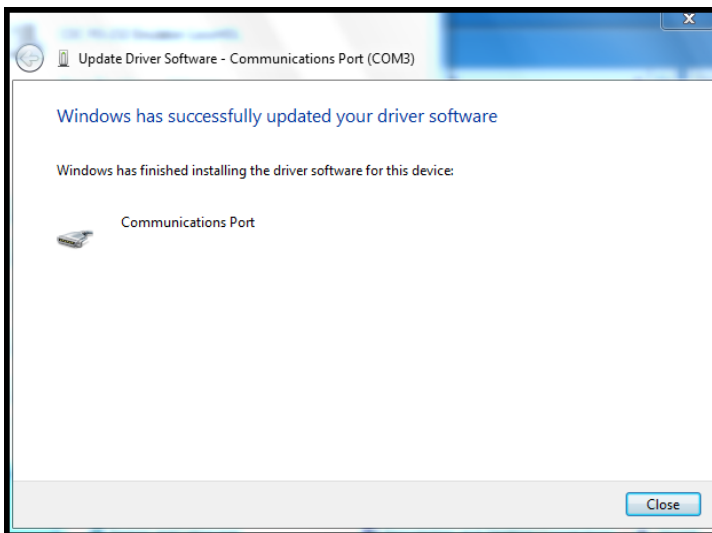

This window appears after the installation.

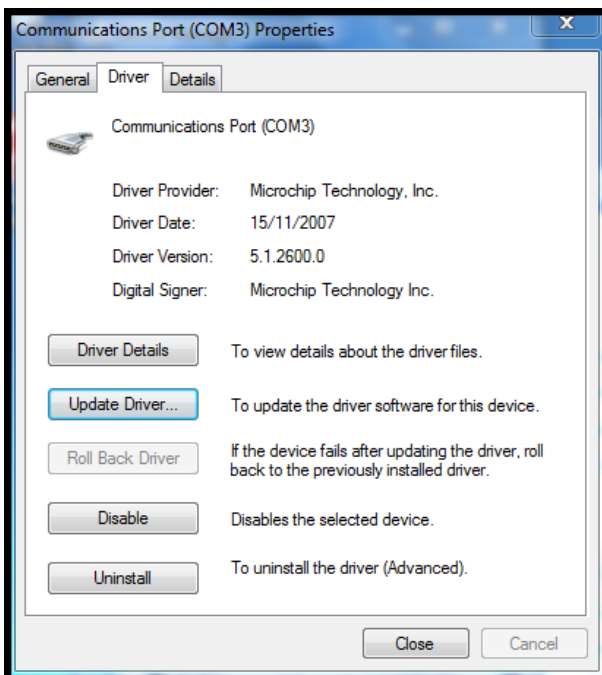

Now you see that the device driver is loaded.

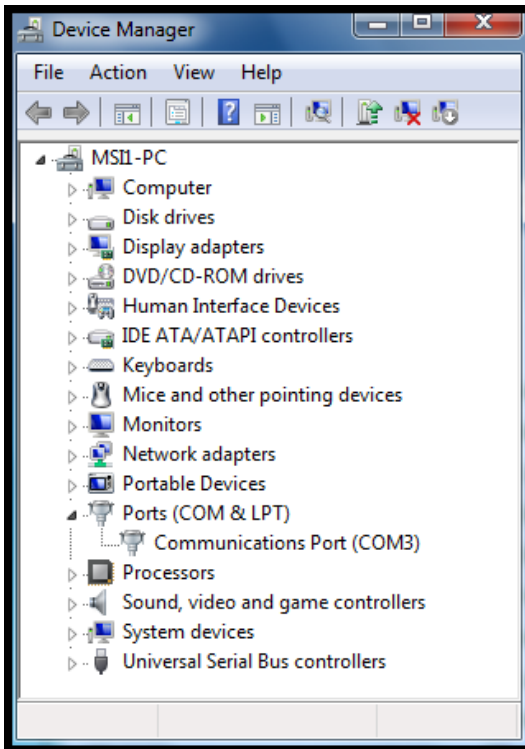

And then to see you that COM port has been produced which you can select in LocoHDL.

Computer setting with USB for Windows 10:

Install first LocoHDL configuration programme version 3.9.6 of higher on your PC.
Connect the LocoBuffer to the computer with a USB cable, put then power on the module.

iTrain setup:

